

FugakuNEXT applications and co-design

- status and prospect -

ISC 2026

2026.6.26

Yasumichi Aoki

Field Theory Research Team /

Next-Generation HPC Application Development Unit,

RIKEN Center for Computational Science (R-CCS)

- **FugkuNEXT basic design**
- **Roadmap** from feasibility study to start operation (2022-2030)
- **Application Area** structure and relation with other areas
- **SubWG1~8** organization and relation with domestic science community
- **Application Spectrum** and its change, forecast is difficult
- **HPC applications for codesign - Early Evaluation Applications (EEA)**
- **Co-design items**
- **Co-design challenges** and our scheme to tackle them
- **Collaboration with Fujitsu and NVIDIA on EEA**
- **CX framework environments**
- **Collaborations** with computer and computational science community
 - latter may get boosted through AI4S
- **Summary and Outlook**

System Performance to be Targeted for FugakuNEXT

FugakuNEXT Goal

Summary by MEXT Committee of HPCI Plan & Promotion

- **5 to 10x higher effective performance** than Fugaku for existing HPC applications
- **Effective performance of 50 EFLOPS or higher for AI processing** with **Zetta-FLOPS-scale** peak performance in mind

Concept

- **"Application First" philosophy** that prioritizes application performance – **"co-design"**
- **Heterogeneous architecture** combining power-efficient CPUs and bandwidth-oriented GPUs to achieve the goal under power constraint
- CPUs that **can utilize the assets such as application software** developed for "Fugaku"

Items	CPUs	GPUs	Fugaku	Improvements
Total node count	≥ 3,400		158,976	
Theoretical peak perf. of FP64 vector	≥ 48 PFLOPS	≥ 3.0 EFLOPS	488-537 PFLOPS	x5.7~
Theoretical peak perf. of FP16/BF16 matrix	≥ 1.5 EFLOPS	≥ 150 EFLOPS	1.95-2.15 EFLOPS	x70.5~
Theoretical peak perf. of FP8 matrix	≥ 3.0 EFLOPS	≥ 300 EFLOP	—	
(Sparsity considered FP8 matrix)	—	≥ 600 EFLOPS	—	
Main memory capacity	≥ 10 PiB	≥ 10 PiB	4.85 PiB	x4.1~
Main memory bandwidth	≥ 7 PB/s	≥ 800 PB/s	163 PB/s	x4.9~
System power consumption	40 MW (compute node and storage)		about 30 MW	

Compute Node Design

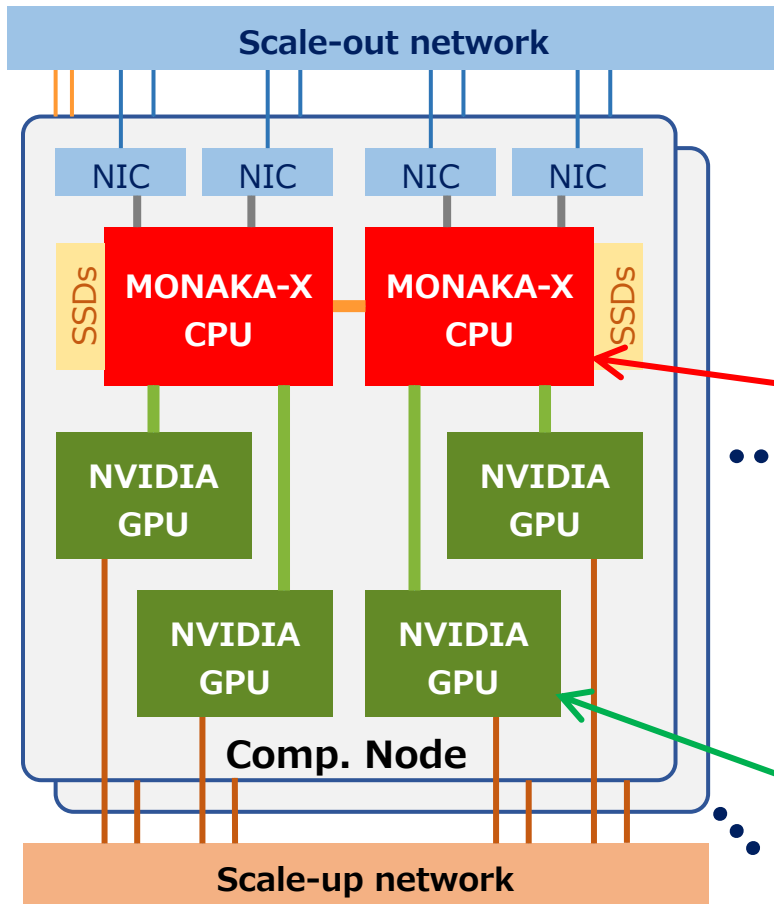

Node design study (CPU-to-GPU ratio)

- 2 CPUs : 4 GPUs as a promising option in terms of node memory size and inter-CPU BW

Co-design for node design exploration



- Candidate options and specs selected for some CPU components
- Remaining specs continue to be refined through co-design

Fujitsu-MONAKA-X CPU design



- Chiplet-based ARM many-core CPU for high performance, low power, and low cost
- Study for ARM SVE and SME
- Study of memory options with different capacity/bandwidth characteristics together with node packaging design
- NVLink-C2C considered as high-BW coherent CPU-GPU interconnect

GPU design



- Evaluation of SM and Tensor Core specifications
- Investigation of memory options with different capacity/bandwidth characteristics
- Exploration of advanced stacked-memory technologies

Road to Achieving up to 100x Application Performance

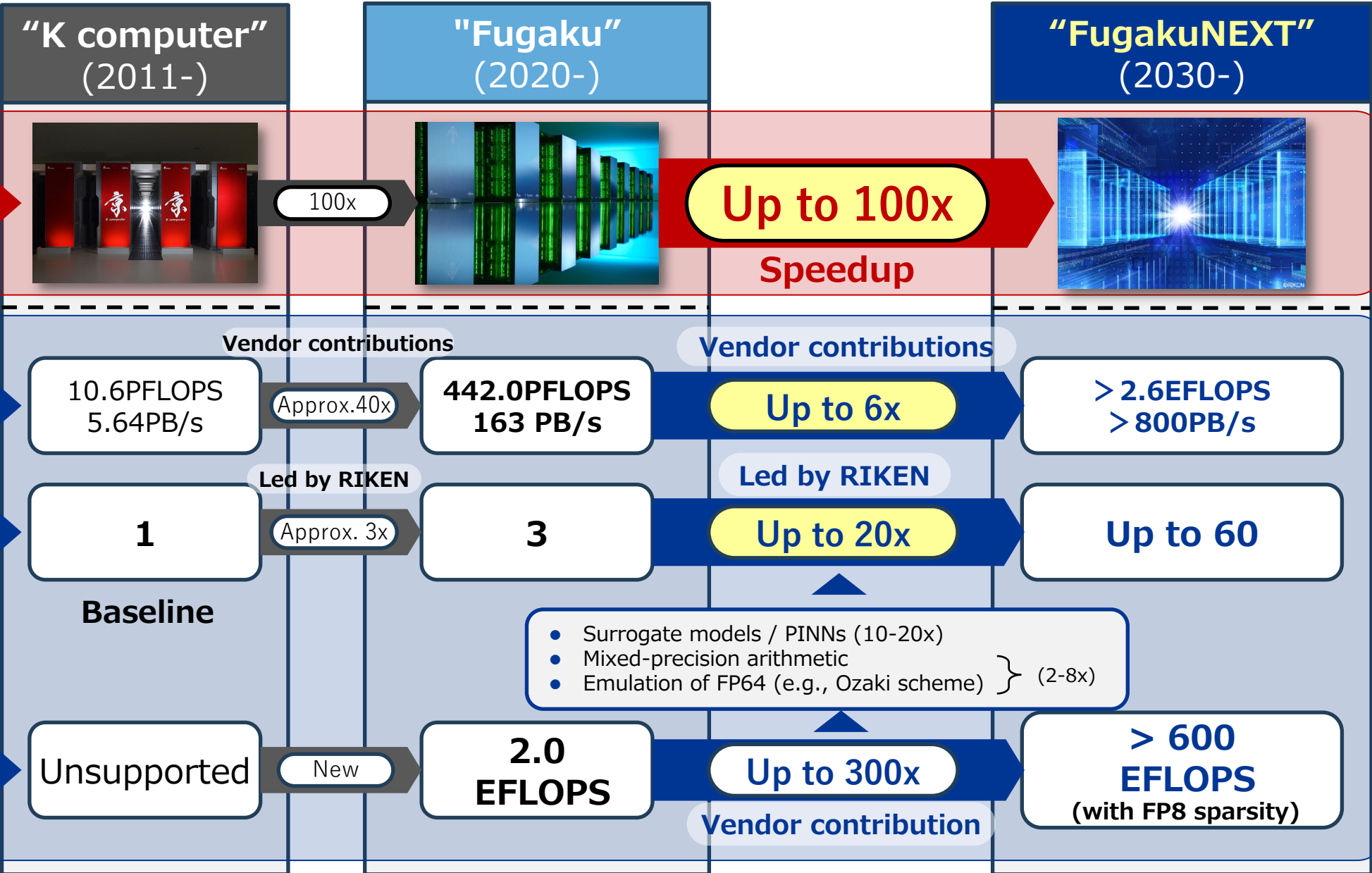

Vendor contributions

Vendor contributions

Led by RIKEN

Led by RIKEN

- Surrogate models / PINNs (10-20x)
- Mixed-precision arithmetic
- Emulation of FP64 (e.g., Ozaki scheme) } (2-8x)

Vendor contribution

Expected Timeline of Fugaku-NEXT R&D @ 2022

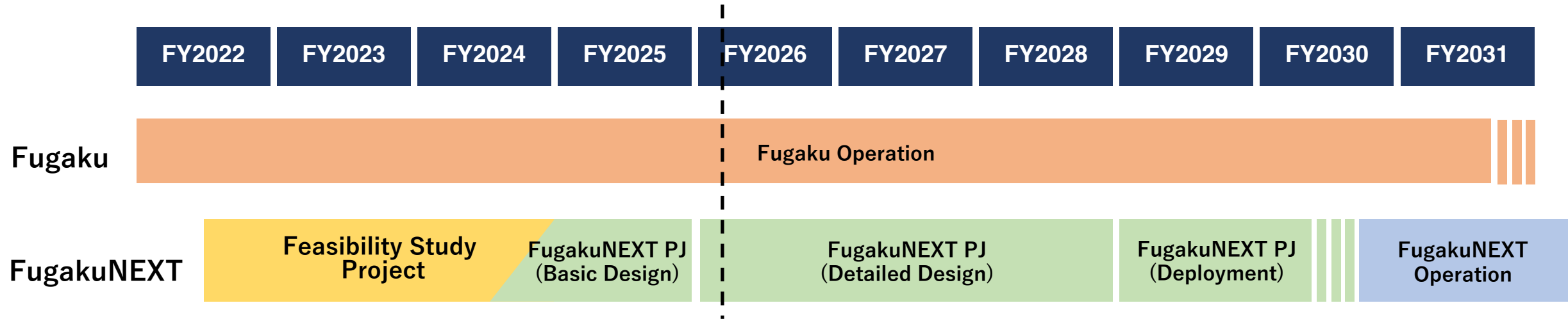

- Launched development project of FugakuNEXT in Jan, 2025, to start **operation in 2030**
 - Establish a project organization built upon the existing collaboration structure
- Initial targets made based on findings in the feasibility study
 - System performance, system software development, application challenges, and others
 - In RIKEN, studying HPC-Quantum hybrid platform continuously to extend computable problems
- **Public tenders for basic design**
 - Overall system, computing nodes, and CPUs
 - Accelerators (GPUs)



Feasibility Study(FY2022-24): Organization Chart [RIKEN]

System Research Team
 (Representative Institution) RIKEN R-CCS
 [PI: M. Kondo, AD: S. Matsuoka(R-CCS)]

GL: Group Leader
 AD: Advisor
 SGL: Sub Group Leader

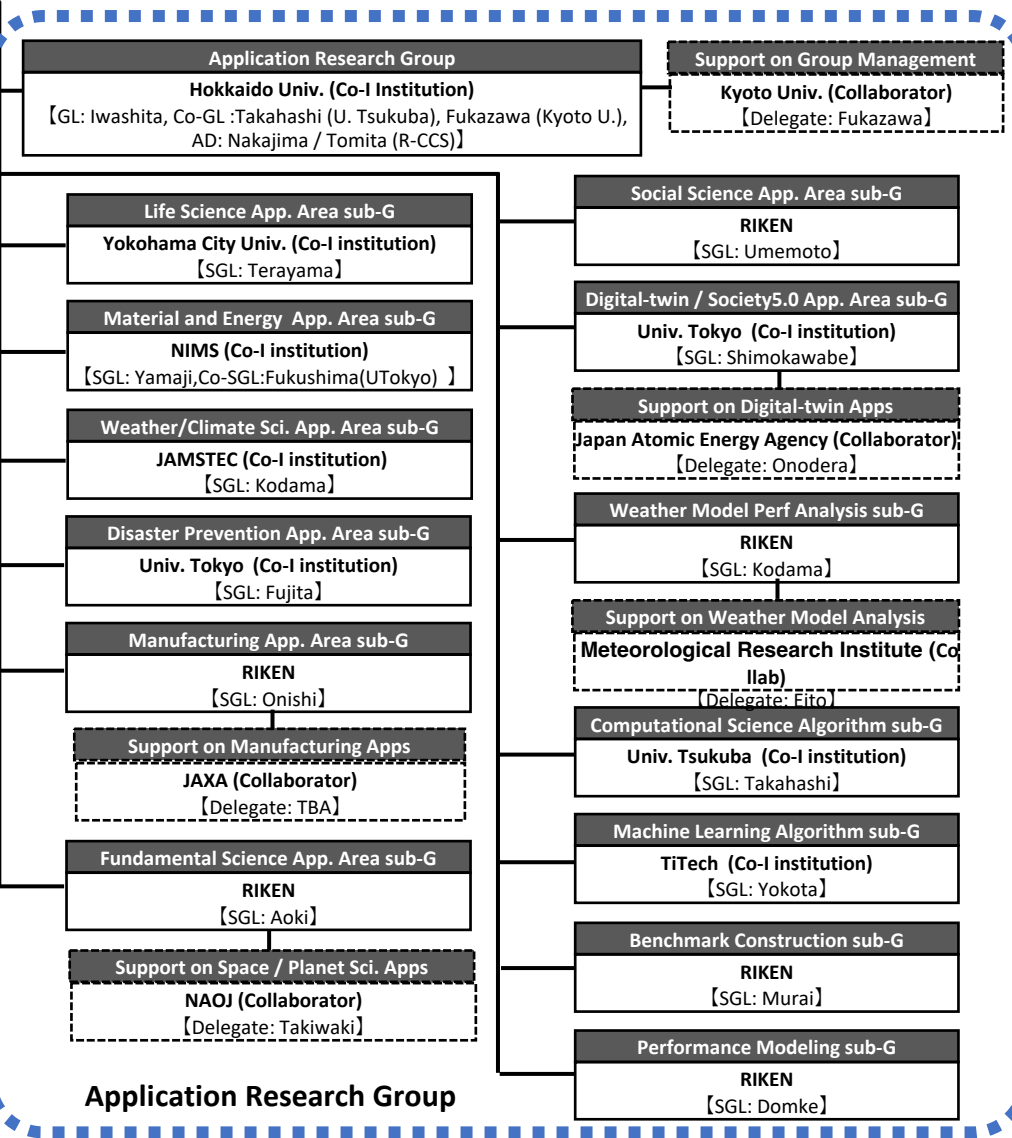
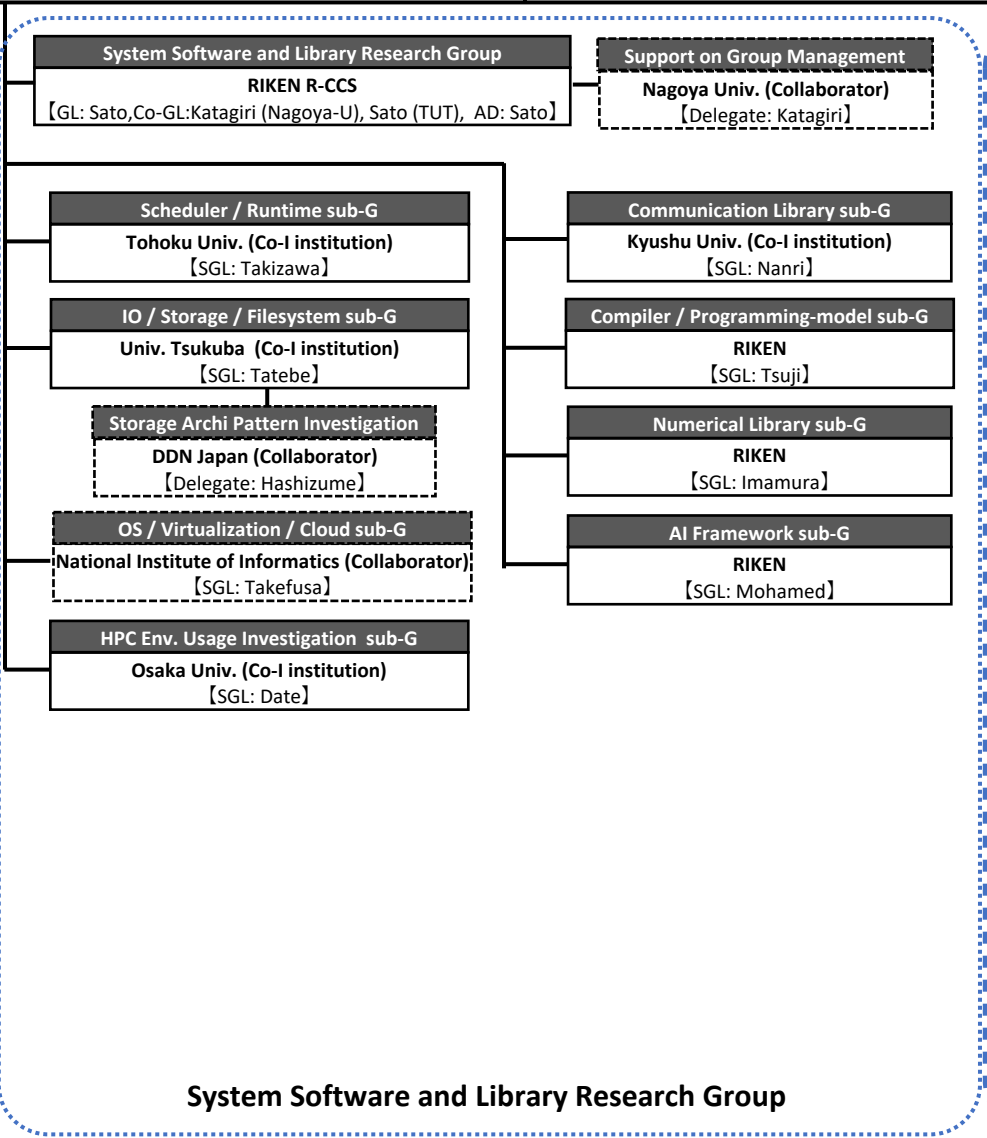
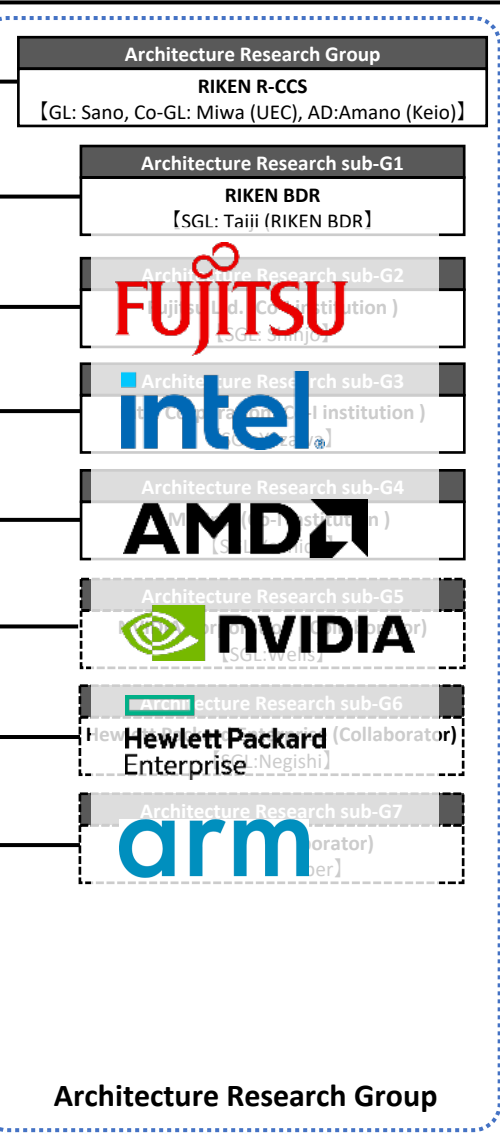

Structure of Application Area Now (FY2025-)

Application Development Unit
UL Yasumichi Aoki

Structure inherited from the Feasibility Study (mostly), Benchmark as WG

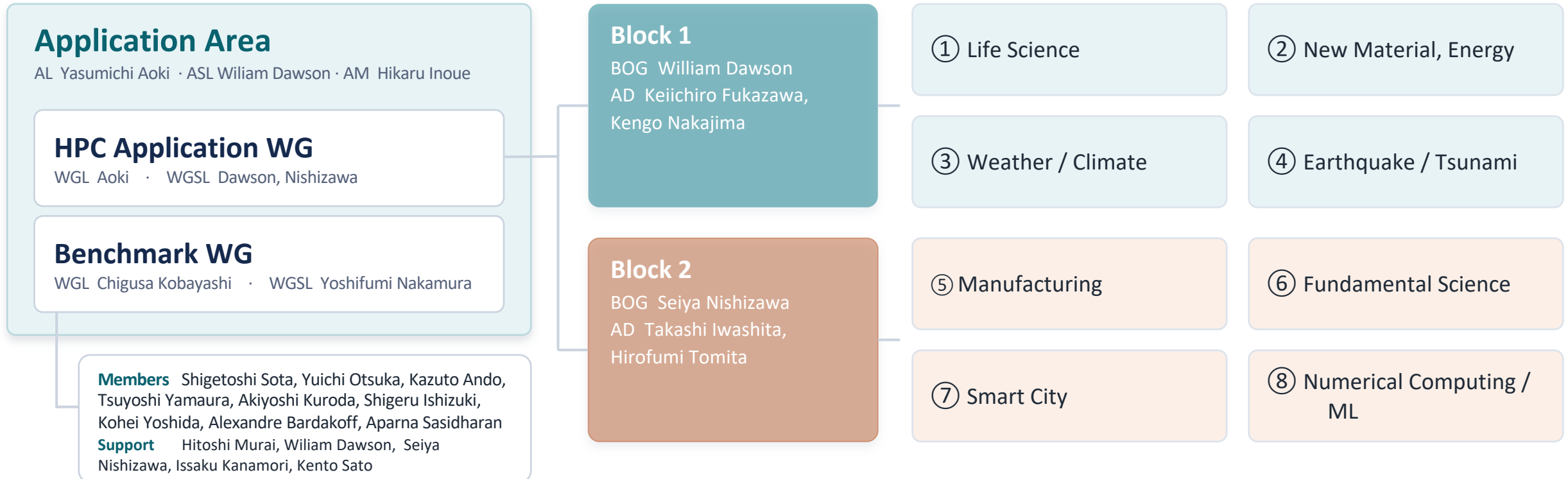

Structure inherited from the Feasibility Study (mostly); Benchmark organized as a WG. SubWG details on the next slide.

Area / Working Groups system (esp. co-design)

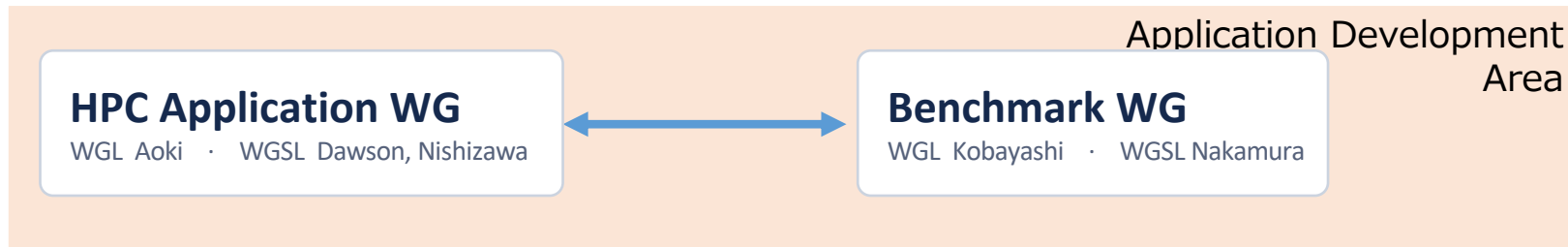

Area / Working Groups system (esp. co-design)

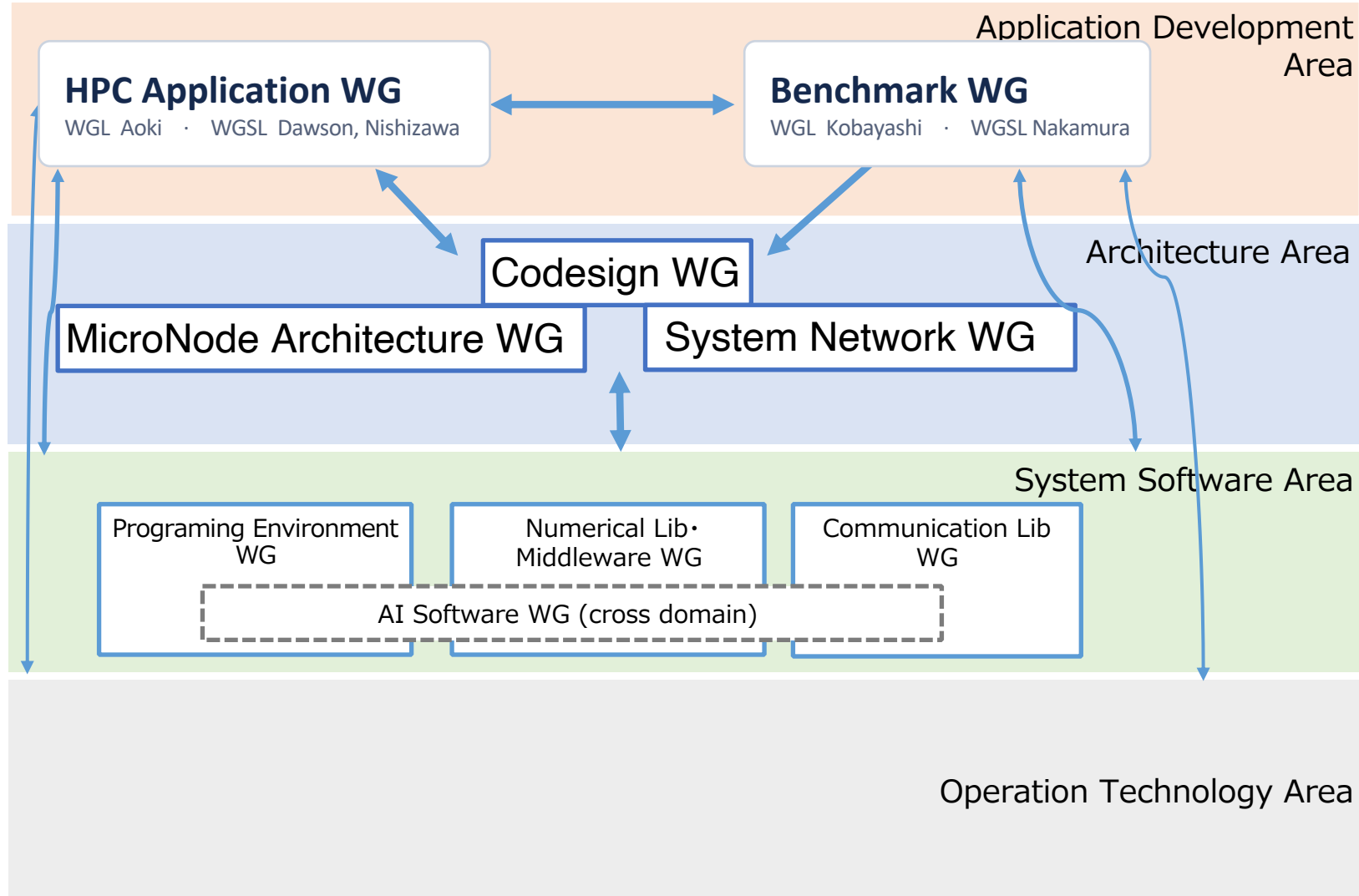

FugakuNEXT HPC Application WG

Sub-Working Groups (①–⑧)

Block 1 William Dawson

① Life Science

Sugita team, Tama team

Shingo Ito [OG], Kei Terayama [LS], *Wenyang Zhao*, Chigusa Kobayashi[SP]

② New Material, Energy

Nakajima team, Yunoki team

William Dawson [OG], Youhei Yamaji [LS], Hidehiko Kohshiro, *Enhua Xu*, Shigetoshi Sota[SP], Yuichi Otsuka [SP]

③ Weather / Climate

Tomita team, Miyoshi team

Seiya Nishizawa [OG], Chihiro Kodama [LS], Sachiho Adachi, Yuta Kawai, James Taylor, Tristan Erwan Hascoet, Shun Ohishi, Shigenori Otsuka, *Unashish Mondal*, Tsuyoshi Yamaura[SP]

④ Earthquake / Tsunami Disaster Mitigation

Tomita team 2

Kohei Fujita [OG, LS], Shigeru Ishizuki[SP], Chigusa Kobayashi[SP]

Block 2 Seiya Nishizawa

⑤ Manufacturing

Tsubokura team

Junya Onishi [OG], Ryoji Takaki [LS], Chisachi Kato [AD], Peter Brian Ohm, Kazuto Ando[SP]

⑥ Fundamental Science

Aoki team

Issaku Kanamori [OG, LS], Tomoya Takiwaki [LS], Yoshifumi Nakamura[SP]

⑦ Smart City

Social Science, Digital Twin / Society 5.0 · Yamaguchi team

Hirozumi Yamaguchi [OG, LS], Fukuharu Tanaka, Takashi Shimokawabe [AD], Shigeru Ishizuki[SP], Chigusa Kobayashi[SP]

⑧ Numerical Computing Tech. / ML Algorithm

Imamura team

Atsushi Suzuki [OG], Daisuke Takahashi [LS], Rio Yokota, Akiyoshi Kuroda[SP] (+ some more from System WG)

FugakuNEXT HPC Application WG structure - examples

① Life Science

Sugita team, Tama team

Shingo Ito **[OG]**, Kei Terayama **[LS]**, *Wenyang Zhao*, Chigusa Kobayashi[SP]

⑤ Manufacturing

Tsubokura team

Junya Onishi **[OG]**, Ryoji Takaki **[LS]**, Chisachi Kato **[AD]**, Peter Brian Ohm, Kazuto Ando[SP]

⑥ Fundamental Science

Aoki team

Issaku Kanamori **[OG, LS(particle, nuclear)]**, Tomoya Takiwaki **[LS(astro, planetary)]**, Yoshifumi Nakamura[SP]

Roles

- OG** Organizer (R-CCS orig. member(mostly) · coordination & cooperation)
- LS** Liaison (community cooperation)
- AD** advisor
- SP** supporting member from Benchmark WG

Application Spectrum from Current Fugaku Statistics

Fugaku usage – FY2024
(HPCI General Subject

$$= [R5-B] + [R6-A] + [R6-B]$$

Fugaku Node-hours — Annual Total by Category (FY2024)

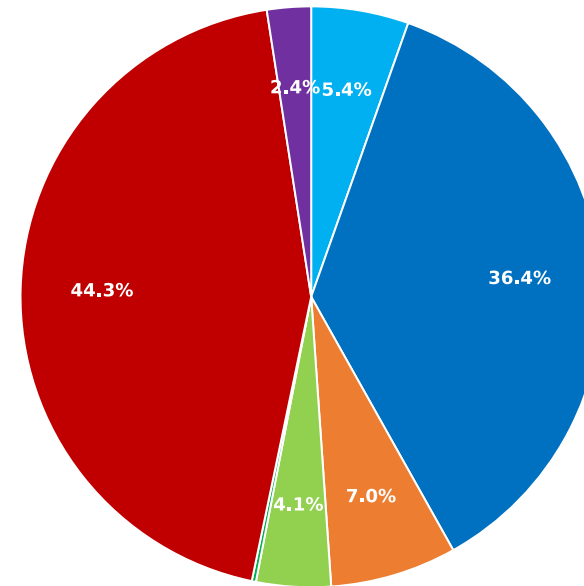
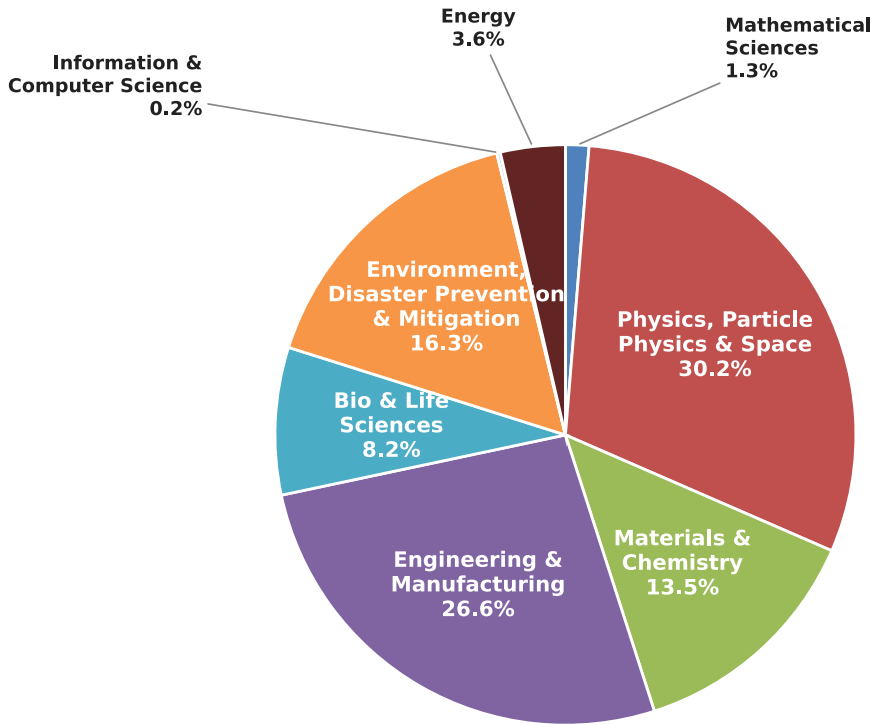

- R5-B Term Projects
- R6-A Term Projects
- R6-B Term Projects
- Trial Access Projects (Free)
- Trial Access Projects (Paid)
- Program for Promoting Researches
- Policy-Driven Projects

Application SubWG representing HPC communities

Fugaku usage – FY2024 (HPCI General Subject)

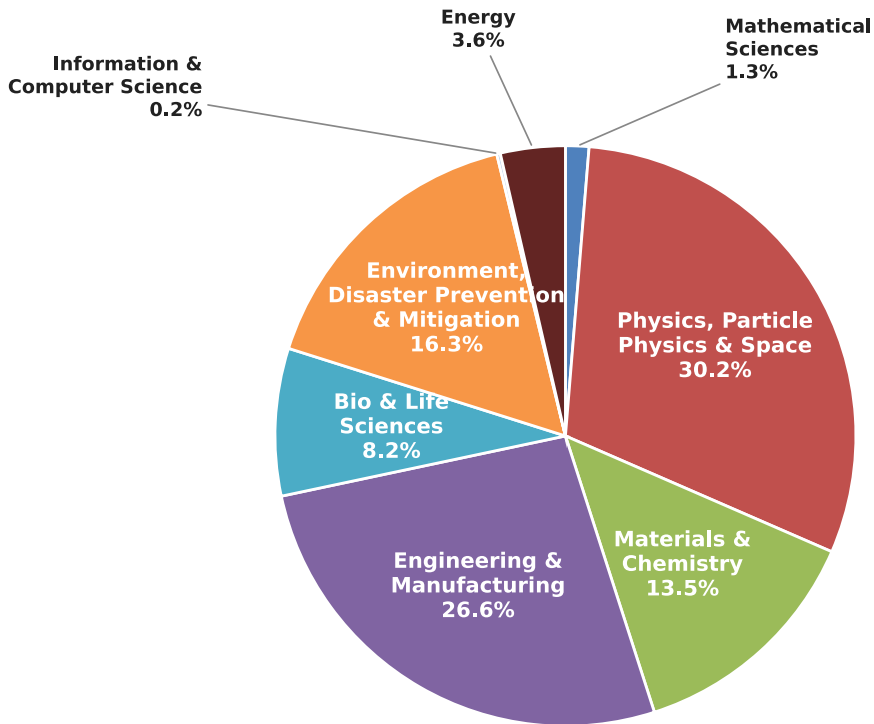

HPC Applications at Fugaku

– covered by SubWGs1~7

- Particle Physics & Space SubWG6
- Materials & Chemistry SubWG2
- Engineering & Manufacturing SubWG5
- Bio & Life Sciences SubWG1
- Environment & Disaster Mitigation SubWG3, 4
SubWG7

Application Spectrum

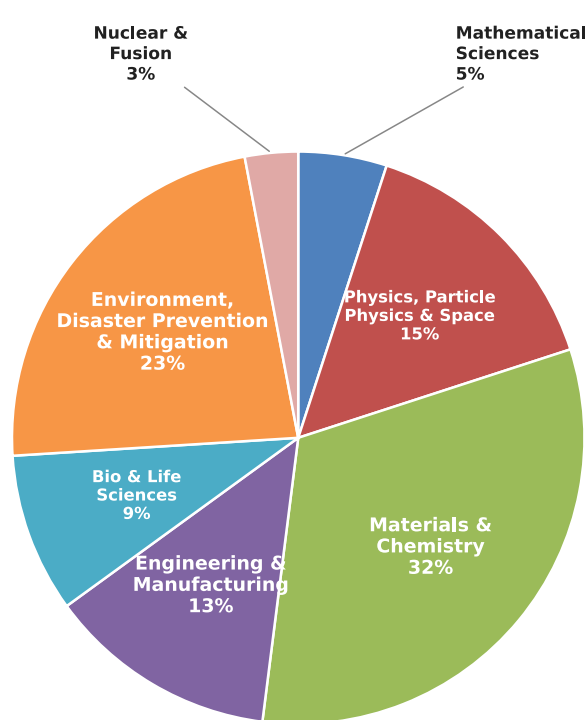

FY2014

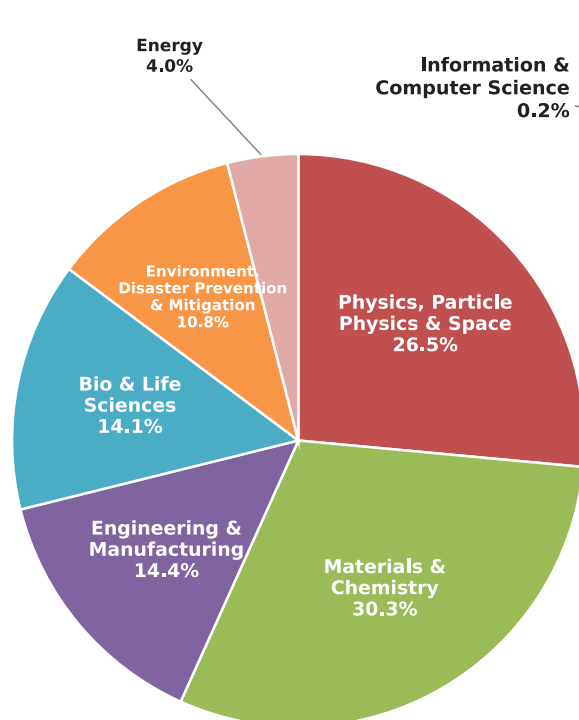

FY2019

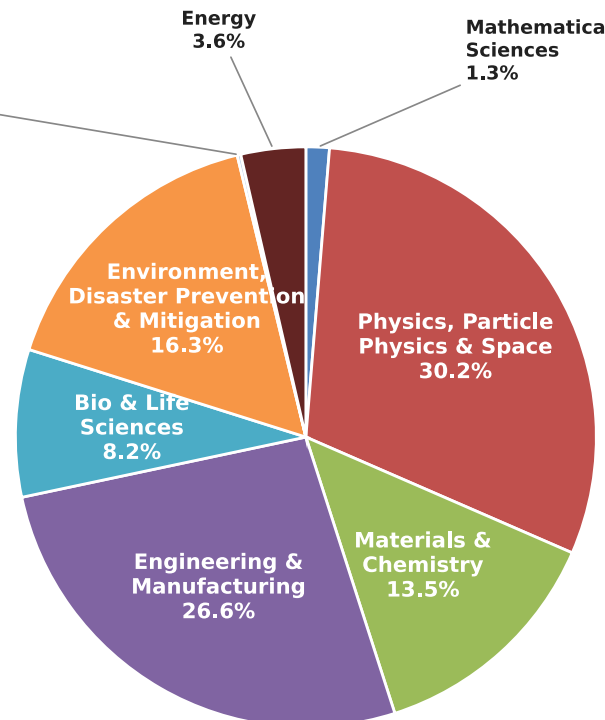

FY2024



FY2030

Early Evaluation Applications for Co-Design

Application	Domain	Description	Characteristics
Genesis	Life Sciences	Molecular dynamics simulation	3
UT-Heart	Life Sciences	Cardiac electrophysiology and electromechanical coupled simulation	5, 6
SALMON	New Materials&Energy	First-principles electronic structure calculation (TDDFT)	5
mVMC	New Materials&Energy	Strongly correlated electron system simu. using quantum Monte Carlo	1
SCALE-LETKF	Weather & Climate	Weather simu. and data assimilation (Local Ensemble Kalman Filter)	1, 4, 5
E-Wave	E-quake&Disaster Prev.	Seismic wave propagation simulation	6
FrontFlow/blue	Manufacturing	Fluid analysis using unstructured grid finite volume method (CFD)	6
FFVHC-ACE	Manufacturing	High-fidelity fluid analysis using unstructured grid finite volume method	5
LQCD-DWF-HMC	Basic Science	Lattice QCD simulation (Domain-Wall Fermion, HMC)	5
MHDTurbulence	Basic Science	Magnetohydrodynamic turbulence simulation	5
Sionna + SUMO	Smart City, D-Twin	Digital twin / large-scale social simulation	5, 6
PETSc	Sci & ML Algorithms	Large-scale parallel linear solver framework	—
PyTorch/Megatron	Sci & ML Algorithms	Large-scale language model training (distributed DL framework)	—

1. Matrix-multiplication (high computational intensity)
2. Low B/F, simple loop
3. Cache-blocking applicable

4. Low B/F with complex loop structure
5. High B/F with contiguous memory access
6. High B/F with indirect memory access

Overview and Status of System Co-design

- Establish **the design space** and implement **co-design items** with the application area
 - Design space = Combination of technology and performance options
- **Examples of technical items within the design space established to date**
 - CPU performance (computational, memory performance, etc.)
 - GPU performance (computational, memory performance, etc.)
 - CPU-GPU interconnect
 - Node configuration
 - Scale-up configuration (domain size, etc.)
 - Scale-out configuration (injection bandwidth, etc.)
- **Comprehensively evaluate benefits, costs, and risks to select the primary candidate**
 - Benefits: Application performance, performance portability, productivity, etc.
 - Cost and Risk: Technical feasibility and risks, schedule delays, manufacturing costs, etc.

FugakuNEXT co-design challenges

- **Application Developers – Fugaku users**

- Fugaku is a CPU machine – GPU porting / tuning (from scratch)
- AI utilization for various levels (chances)

- **RIKEN**

- co-design w/ well-balanced application spectrum
 - *GPU ready & tuned applications are not many*
- Hard to forecast application spectrum in ~2030
 - *Especially on AI use / utilization – being developed so fast*
 - Good use cases may arise from outside of current HPC community
- Make the project transparent amap <-> co-design of Fugaku
- Handling critical information
- Heavy demand of GPU env / Current JP resources

FugakuNEXT co-design scheme

- **Application Developers – Fugaku users**
 - Fugaku is a CPU machine – GPU porting / tuning (from scratch)
 - AI utilization for various levels (chances)
- **RIKEN**
 - co-design w/ well-balanced application spectrum
 - *GPU ready & tuned applications are not many*
 - Hard to forecast application spectrum in ~2030
 - *Especially on AI use / utilization – being developed so fast*
 - Good use cases may arise from outside of current HPC community
 - Make the project transparent amap <-> co-design of Fugaku
 - Handling critical information
 - Heavy demand of GPU env / Current JP resources
- **Application Developer Support**
 - Porting Tuning Support
 - *EEA1 – Fujitsu and NVIDIA tuning support*
 - *Porting / Tuning Support in person, AI use(plan)*
- **Co-design objectives**
 - Balance of Applications
 - *Check balance and add important apps*
 - To be Ready for 2030 spectrum and balance
 - *Include various AI workloads*
 - *Grand Reach Program Applications*
 - *Seek use case in AI for Science (2026-)*
 - Transparency
 - *Document / Environment to be made open*
 - Information Security
 - *Environments – Internal use / Open public*
 - *Capable CX environment prepared*
 - GPU Resources *being increased*

Early Evaluation Application I (EEA1) for profiling and Co-design w / [NVIDIA]

Block	Application	Description	GPU readiness	Proxy for GPU evaluation	Comp. Category
SubWG1 – Life Science	Genesis	Molecular Dynamics Simulation 分子動力学シミュレーション	✓ (CUDA)		3
SubWG2 – New Material, Energy	SALMON	Scalable Ab-initio Light-Matter simulator for Optics and Nanoscience	✓ (OpenACC) - new implementation.	SPARC	5 (stencil, small matrix), sometimes 6 (fft).
SubWG3 – Weather/Climate	SCALE-LETKF	Coupled weather simulation (WS) and data assimilation (DA) application	The simulation part has been implemented (with insufficient optimization), and the data assimilation part is currently under consideration	simulation part: EAMxx	5: weather simulation dynamics part (FVM) 4: weather simulation physical process 1: data assimilation (many small-sized dgemm)
SubWG4 – Earthquake/Tsunami Disaster Mitigation	E-Wave	Earthquake Simulation	✓ (OpenACC) Fully Optimized		6 (Note that algorithmic improvements to reduce the B/F value are being worked out)
SubWG5 – Manufacturing	FrontFlow/blue	CFD	✓ (OpenACC)		6 (FEM)
SubWG6 – Fundamental Science	LQCD-DWF-HMC	Hybrid Monte-Carlo algorithm of domain wall fermions in Lattice QCD	Partly Done	Grid, QUDA	5

GPU evaluation

Scale-Up Network eval.

Early Evaluation Application I (EEA1) for profiling and Co-design w / [Fujitsu]

Block	Application	Description	GPU readiness	Proxy for GPU evaluation	Comp. Category
SubWG1 – Life Science	Genesis	Molecular Dynamics Simulation 分子動力学シミュレーション	✓ (CUDA)		3
SubWG2 – New Material, Energy	SALMON	Scalable Ab-initio Light-Matter simulator for Optics and Nanoscience	✓ (OpenACC) - new implementation.	SPARC	5 (stencil, small matrix), sometimes 6 (fft).
SubWG3 – Weather/Climate	SCALE-LETKF	Coupled weather simulation (WS) and data assimilation (DA) application	The simulation part has been implemented (with insufficient optimization), and the data assimilation part is currently under consideration	simulation part: EAMxx	5: weather simulation dynamics part (FVM) 4: weather simulation physical process 1: data assimilation (many small-sized dgemm)
SubWG4 – Earthquake/Tsunami Disaster Mitigation	E-Wave	Earthquake Simulation	✓ (OpenACC) Fully Optimized		6 (Note that algorithmic improvements to reduce the B/F value are being worked out)
SubWG5 – Manufacturing	FrontFlow/blue	CFD	✓ (OpenACC)		6 (FEM)
SubWG6 – Fundamental Science	LQCD-DWF-HMC	Hybrid Monte-Carlo algorithm of domain wall fermions in Lattice QCD	Partly Done	Grid, QUDA	5

GPU profiling

FugakuNEXT CPU evaluation

Benchmark WG in App. Dev. Area

App. Dev. Area

Application Community

- Application Development Area
- HPCI Consortium
- CPU/GPU Vendors
- HAIRDESC
- Other domestic and international universities and research institutions

AI for Science Div.

AI (for Science) Factory

- **AI for general supports:** General application development and execution support with AI chatbots
- **Advanced development supports:** Program generation, code conversion, and auto-tuning by AI

Benchmarks

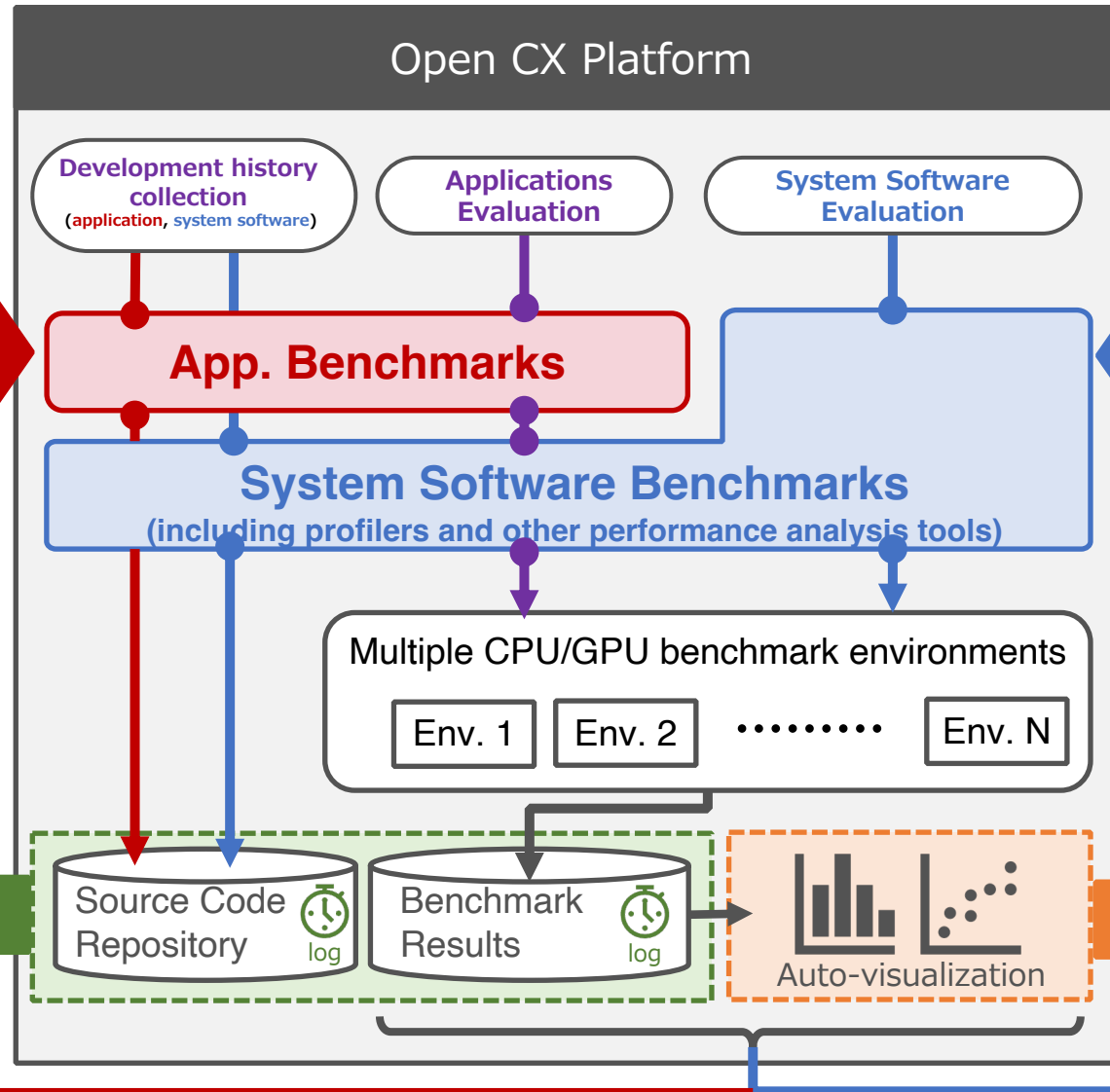

Benchmarks

System Software & Operations Area

Systems software community

- System Software Area & Operation Area
- CPU/GPU Vendors
- AI for Science Platform Division
- Quantum HPC Collaboration Platform Division
- Other domestic and international universities and research institutions

Architecture Area

Open evaluation results and performance project

- $N = N_1 \times N_2 \times N_3 \dots$
- N_1 : CPU/GPU Environment
 - N_2 : Problem Size
 - N_3 : Configurations (compiler, library, version)
 - ...

Feedback of evaluation results to the app/system software community and architecture

Benchmark WG in App. Dev. Area

App. Dev. Area

Application Community

- Application Development Area
- Potential Application developers

Benchmarks

Application Development history collection

Applications Evaluation

Application Benchmarks
(including profilers and other performance analysis tools)

CPU/GPU benchmark environments

Env. 1 Env. 2 ... Env. N

Source Code Repository 
log

Benchmark Results 
log

Auto-visualization  

Architecture Area

- Input for system parameter determination

Feedback of evaluation results to the app/system software community and architecture

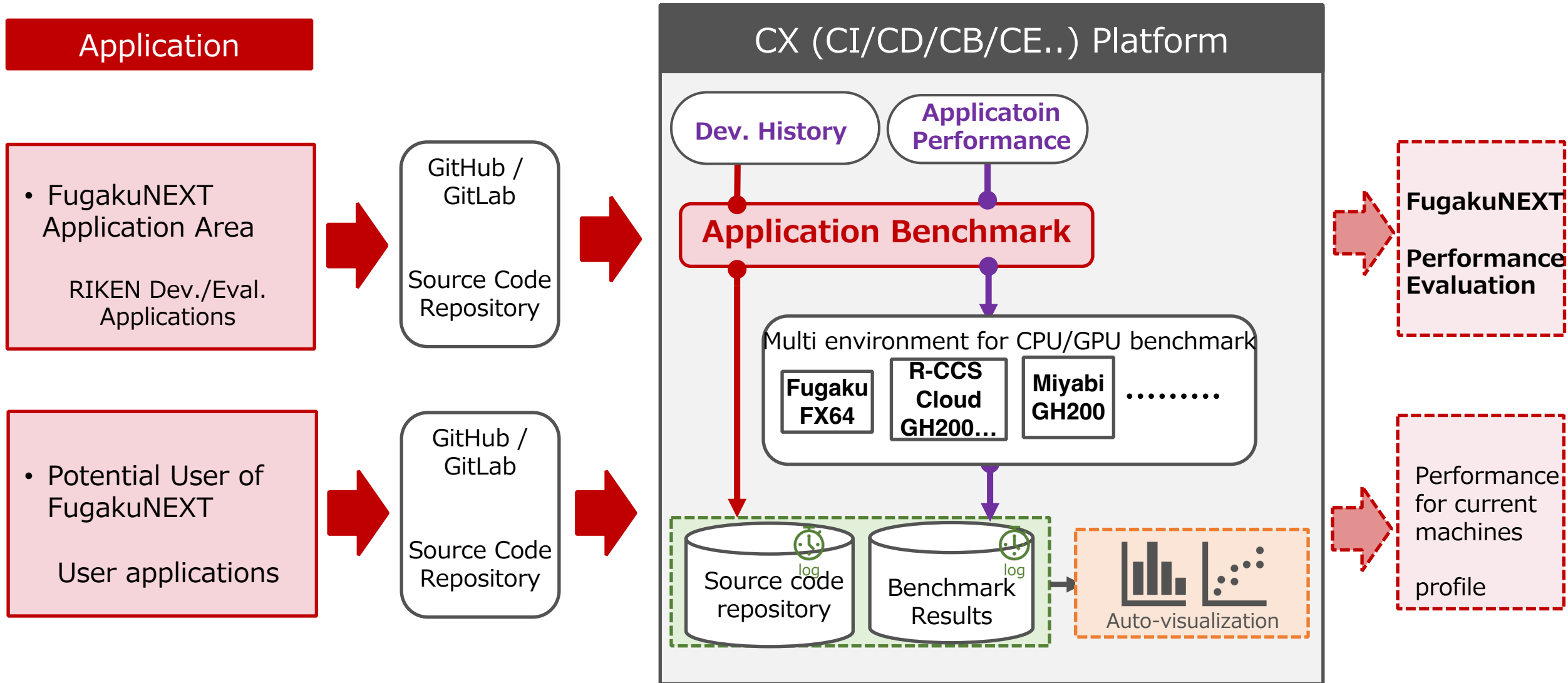

CX framework

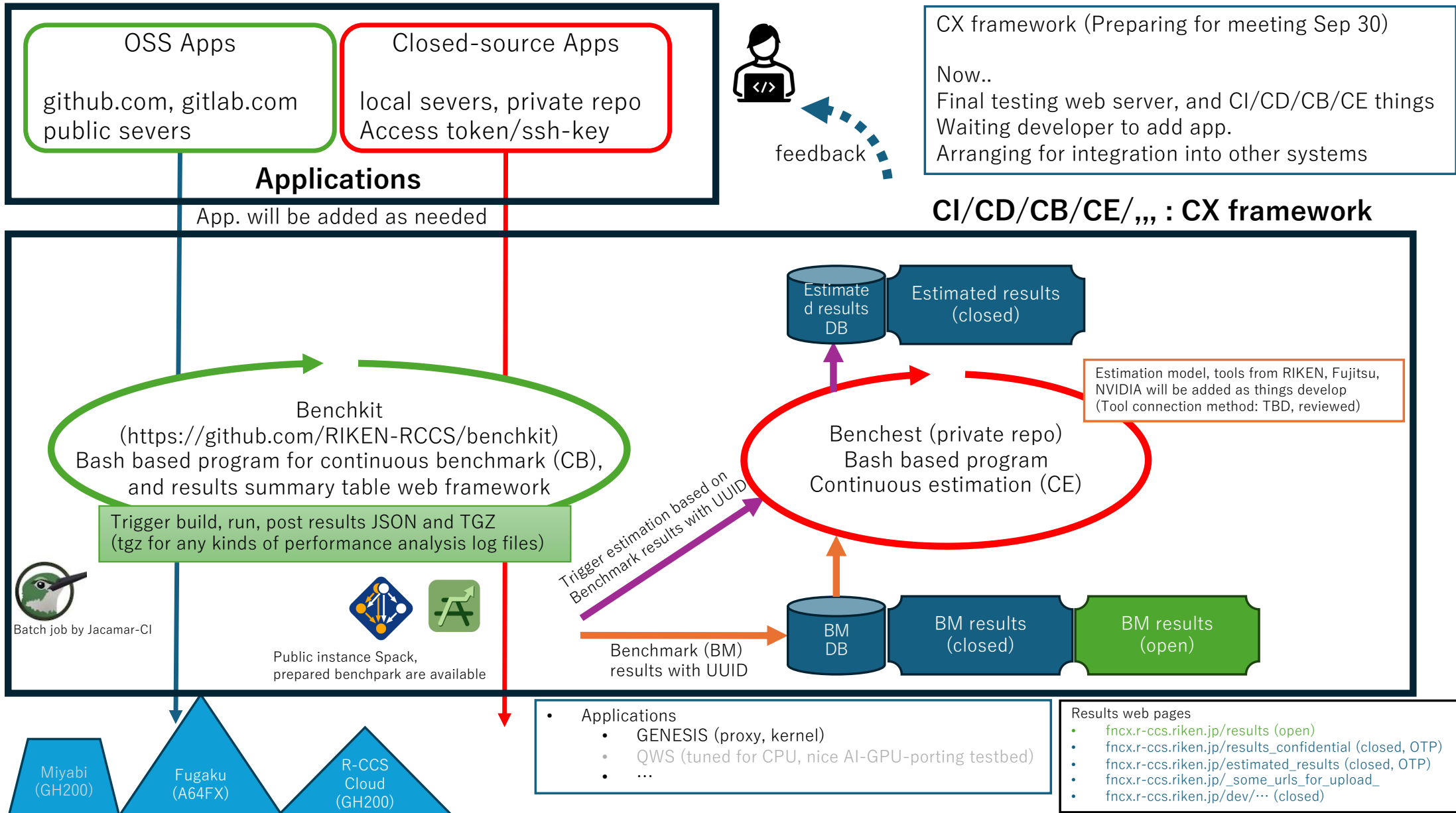

CX systems for FugakuNEXT Application Development

- **Benchmark**
 - <https://github.com/llnl/benchmark>
 - Hackathon [I] for **EEA** developers Jan.22-23,2026 @ R-CCS (Co-organized with DOE Lab. (LLNL))
- **Benchmarkkit**
 - <https://github.com/RIKEN-RCCS/benchmarkkit>
 - Light weight, easy to start with
 - Using Jacamar-CI (ECP)
 - Can utilize Spack, Benchmark
- Performance Evaluation System for FugakuNEXT
 - Being prepared, to be made open for potential FugakuNEXT developers
 - Application needs to put either in Benchmark or Benchmarkkit
 - Eventually integrated into Open CX platform in previous page

2026FY Co-Design Related Milestones & Schedule (Draft)

	Apr	May	Jun	Jul	Aug	Sep	Oct	Nov	Dec	Jan	Feb	Mar
CX Framework	Env.Setup					★ CX Env(α)Release		★ CX Env(β)Release				
	Tech.Spec. Definition	Build for Release		Adjustment		Improvement						
	EEA1 registration			Test & +EEA2 +α		App Developer Support						
	Operational Design		Operational Adjustment(contract,,)			General Application CX Use						
Applica tion dev	EEA1,2 + α Development – SubWG sets milestone											
	Vanguard App Development – AI use (collab w/System Soft Area)											

2026FY Co-Design Related Milestones & Schedule (Draft)

Fugaku Node-hours — Annual Total by Category (FY2024)

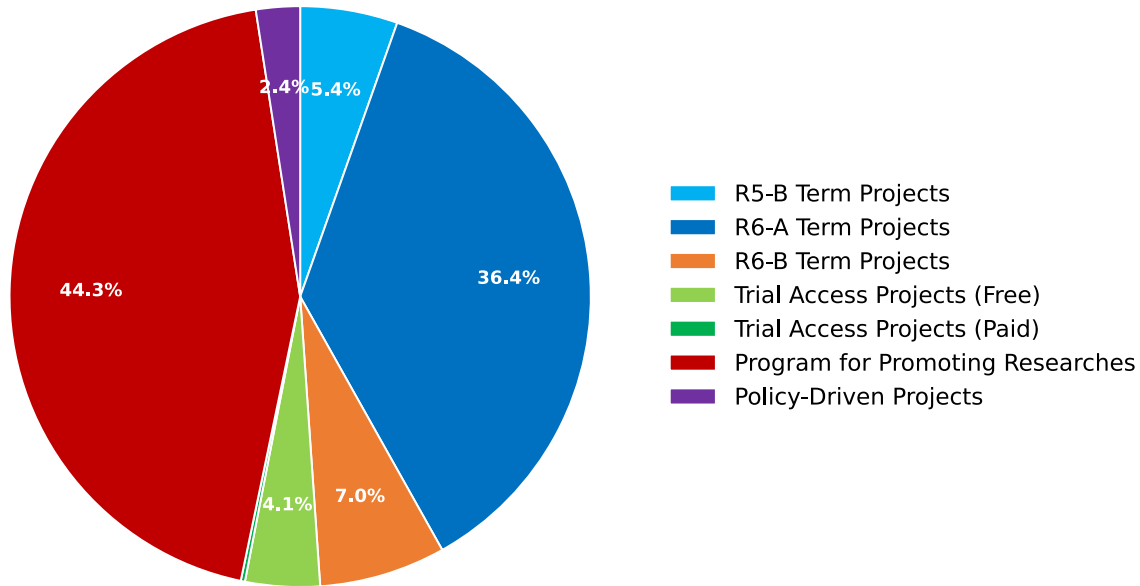

	Sep	Oct	Nov	Dec	Jan	Feb	Mar
★ CX Env(α)Release							
★ CX Env(β)Release							
Improvement							
App Developer Support							
General Application CX Use							
Development – SubWG sets milestone							
Development – AI use (collab w/System Soft Area)							
Application Development - Periodic Meeting 1/month t of who takes care which etc..							
Support for Grand Reach Program (GPU porting)							

Grand Reach Program

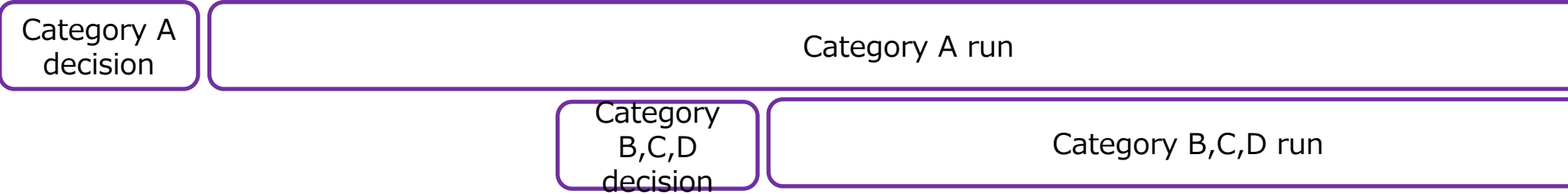

2026FY Co-Design Related Milestones & Schedule (Draft)

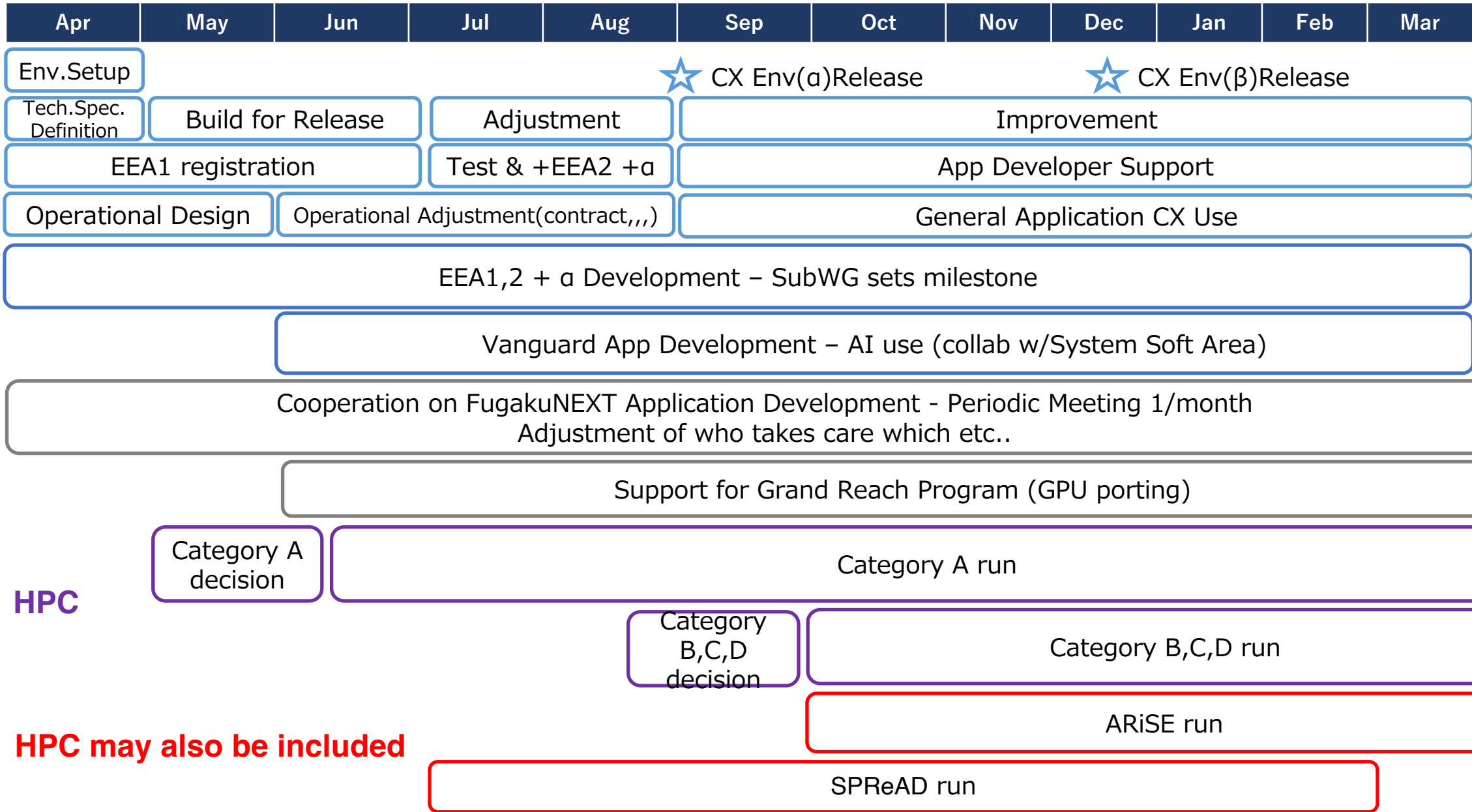

* ARiSE: AI to Redesign Scientific Exploration

* SPReAD: ~ Support Program for Research and Development

HPC-AI Fusion: Future Vision for Advanced Applications

(Example) Accelerating preparedness for disasters such as the inevitable Nankai trough mega-earthquake

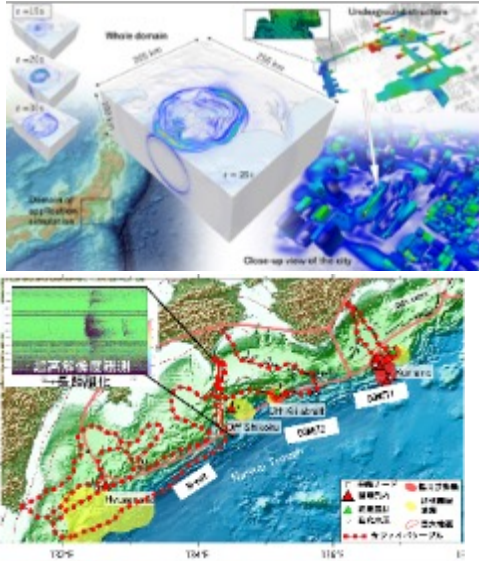

(Example) Hanshin Expressway / Fugaku / SPring-8 / Kyoto University collaboration for highway inspection technology

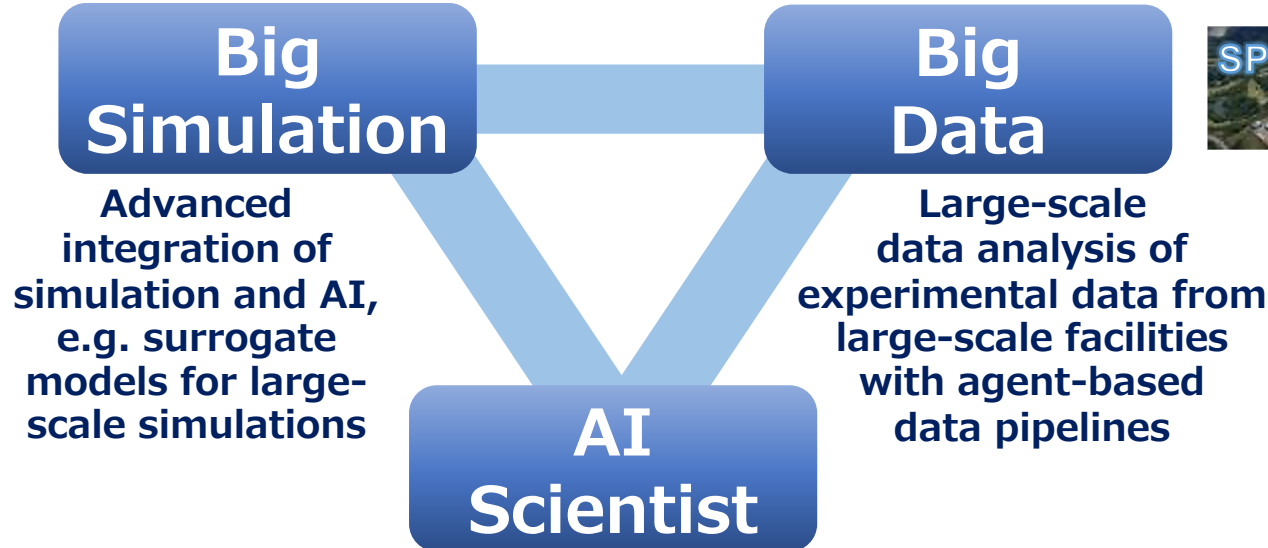
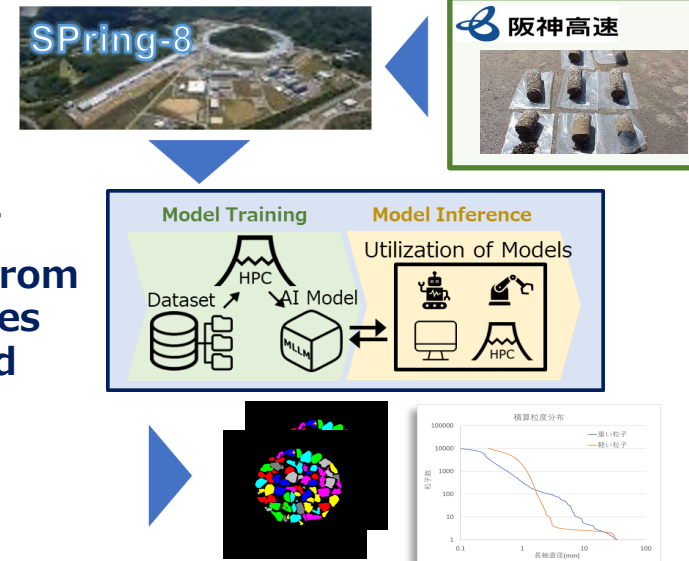

AI autonomously drives the scientific discovery cycle via collaboration among multiple AI scientists.

(Example) Digital twin using real-world aerodynamics simulator

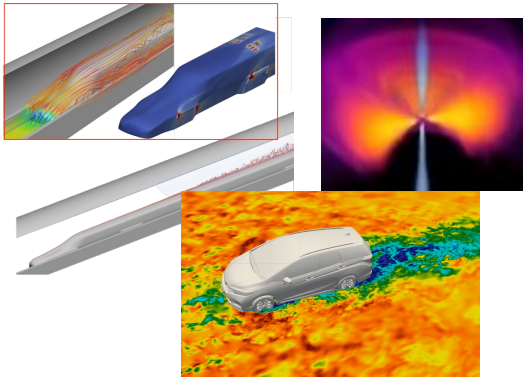

(Example) Life Science DX AI collaborator

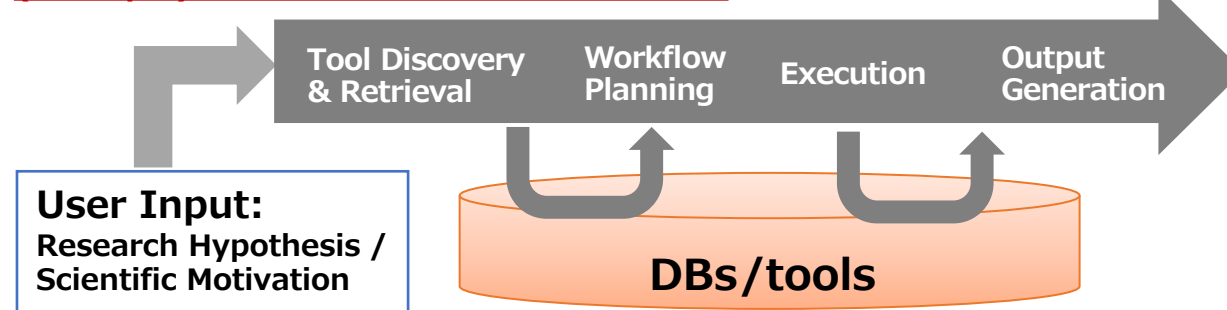

Automated drug discovery

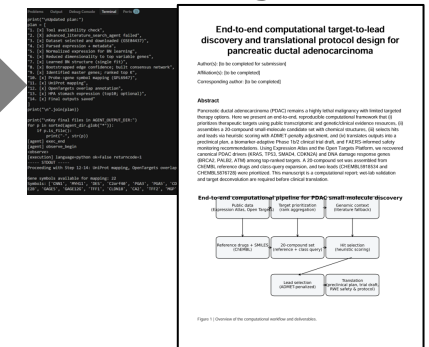

Detailed analysis of required computational resources etc. for AI4S projects is essential.

Relations

- High Performance Computational Science Community [domestic]
 - through SubWG
 - Hearing with leading researchers
- High Performance Computer Science Community [domestic]
 - through other Areas (other than Application Area) in the project
 - HAIRDSC (PI Taisuke Boku @ RIST) regular communication for collaboration
 - Next Generation **HPC** · **AI R&De** Support **C**enter
- HPC [international]
 - DOE Labs (ex: benchpark and Hackathon, Jacamar-CI,,)
 - Other international relations
- These relations are more important and effective for FugakuNEXT system than the previous system

Summary

- **FugkuNEXT basic design**
- **Roadmap** from feasibility study to start operation (2022-2030)
- **Application Area** structure and relation with other areas
- **SubWG1~8** organization and relation with domestic science community
- **Application Spectrum** and its change, forecast is difficult
- **HPC applications for codesign - Early Evaluation Applications (EEA)**
- **Co-design items**
- **Co-design challenges** and our scheme to tackle them
- **Collaboration with Fujitsu and NVIDIA on EEA**
- **CX framework environments**
- **Collaborations** with computer and computational science community
 - latter may get boosted through AI4S
- **Summary and Outlook**

Outlook

- **CX env./ various document and information made public**
- **(future) AI workflow → co-design being considered**
- **Collaboration with AI4S projects with real scientific workflow**
- **Computation characteristics categorization should be refined**

backup

Expected Overall System Architecture

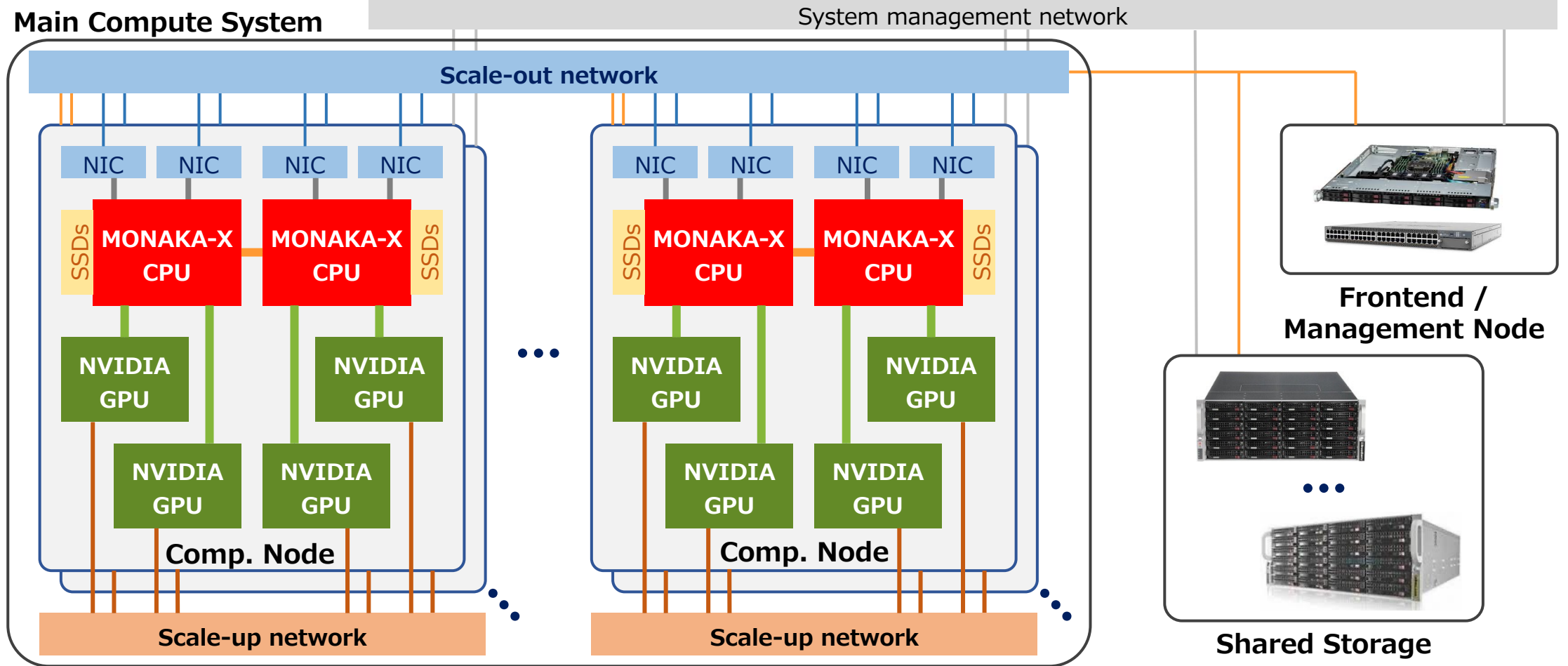

Main Compute System

- Massively parallel nodes with Fujitsu MONAKA-X CPUs and NVIDIA GPUs
- Inter connection via a scale-out NW

Compute Node

- High-BW coherent CPU-GPU interconnect using NVLink-C2C
- NVLink-based scale-up NW

CPU, GPU

- Archi details are now under consideration (e.g.: FP64 vector, low-precision matrix)
- Exploring memory technology options

Scale-out and Scale-up Network Design

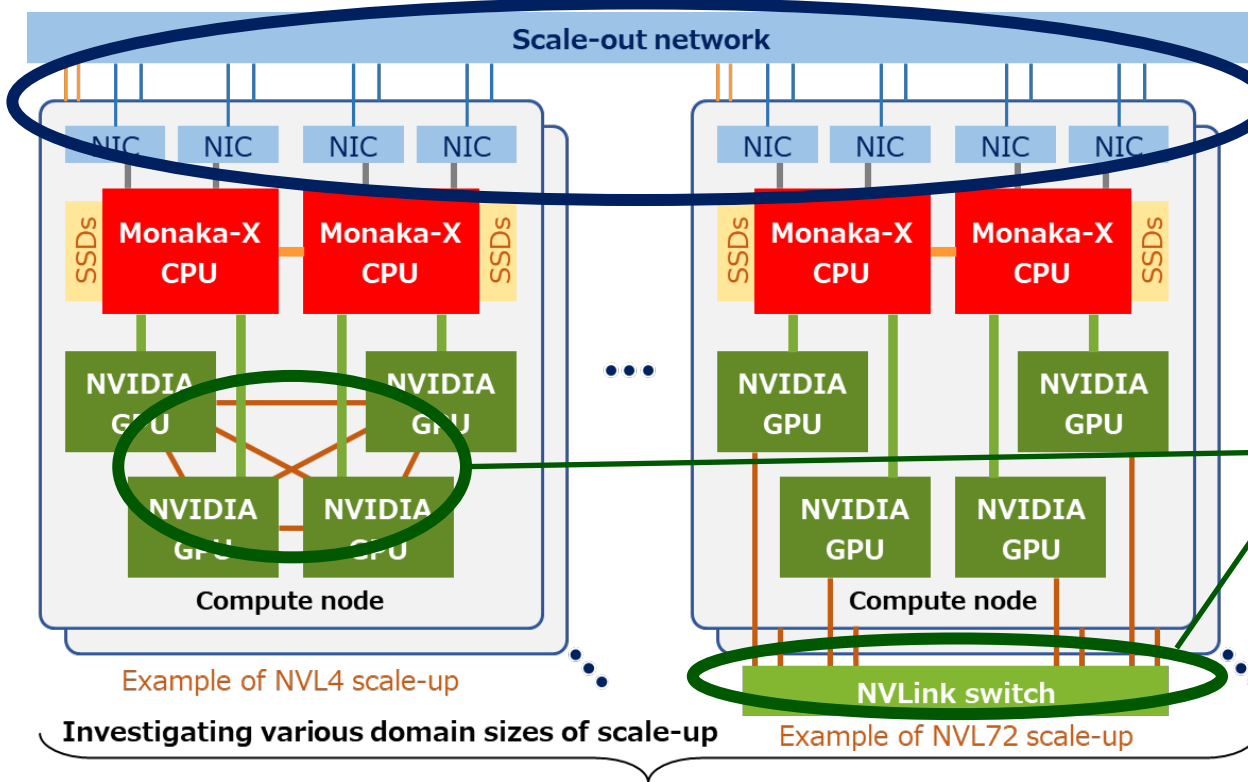

Scale-out network

- **System-wide** interconnection of nodes (or pods)
- **Global**/high latency/limited bandwidth communication with coarse-grained messaging
- **Weak scaling**, increasing total problem size to maximize compute performance rather than reducing runtime
- Explore **tree-based network topologies**

Scale-up network

- GPU interconnect **within a limited node/pod domain**
- **Local**/low latency/high bandwidth communication with distributed shared-memory access
- **Strong scaling**, reducing runtime without increasing total problem size, at higher system cost
- Explore **different scale-up domain sizes** (including mixed configurations)

Scale-up domain size (GPU count) gives different app. performance–cost trade-offs.

GPU count in scale-up domain	small (e.g., NVL4)	large (e.g., NVL72)
Strong-scaling performance	low	high
Scale-up network cost	low	high

Need to investigate how much apps and AI workloads can benefit from scale-up, for strong scaling.

RIKEN-RCCS / benchkit Public

Code Issues Pull requests Actions Projects Security and quality Insights

- Files
- develop
- Go to file
- .github
- benchmark-bridge
- config
- docs
- cx
- deploy
- guides
 - add-app.md
 - add-estimation-packag...
 - add-estimation-to-app...
 - add-estimation.md
 - add-site.md
 - developer-reference.md
 - profiler-level-reference...
 - profiler-support.md
 - ci.md
 - repository-history.md
- programs
 - LQCD_dw_solver
 - MHDTurbulence

benchkit / docs / guides / developer-reference.md

yoshifuminakamura Harden estimator CI runtime checks

Preview Code Blame

Developer Reference

This document is intended for CX Framework and BenchKit developer structural and operational details that are too implementation-focused for the README.

Project Structure

```
benchkit/  
|- programs/  
|  `-- <code>/  
|     |- build.sh  
|     |- run.sh  
|     |- estimate.sh  
|     `-- list.csv  
|- benchmark-bridge/  
|  |- config/  
|  `-- scripts/  
|- result_server/  
|  |- routes/  
|  |- templates/  
|  |- utils/  
|  |- tests/  
|  |- app.py  
|  |- app_dev.py  
|  `-- create_admin.py
```

- Files
- develop
- Go to file
- config
- docs
 - cx
 - deploy
 - guides
 - add-app.md
 - add-estimation-packag...
 - add-estimation-to-app...
 - add-estimation.md
 - add-site.md
 - developer-reference.md
 - profiler-level-reference...
 - profiler-support.md
 - ci.md
 - repository-history.md
- programs
 - LQCD_dw_solver
 - MHDTurbulence
 - ffb

アプリ追加手順 Adding application

このドキュメントは、BenchKit に新しいアプリ（プログラム）を追加する手順を開発者向けにまとめたものです。サンプルアプリ `qws` を参考に、新しいアプリ `<code>` を追加して PR を作成するまでを説明します。

2. アプリの基本構成 Application Structure

ディレクトリ構成

```
programs/<code>/  
├─ build.sh # ビルドスクリプト  
├─ run.sh # 実行スクリプト  
└─ list.csv # 実行条件定義
```

4. ビルドスクリプトの作成 Creating build.sh

build.sh の基本構造

```
#!/bin/bash  
set -e  
system="$1"  
mkdir -p artifacts  
  
# ソースコード取得  
git clone https://github.com/your-org/your-app.git  
cd your-app  
  
# システム別ビルド設定  
case "$system" in  
  Fugaku)  
    # A64FX向けクロスコンパイル  
    make -j 8 compiler=fujitsu_cross mpi=1  
    ;;  
*)  
    ;;  
esac
```

- **多拠点開発基盤構築について / Multi-Site Development Platform: by Yoshifumi Nakamura**

- 第203回ハイパフォーマンスコンピューティング・第17回量子ソフトウェア合同研究発表会

The 203rd High-Performance Computing and the 17th Quantum Software Joint Workshop

Hokkaido Univ. / Online – March 16-18, 2026

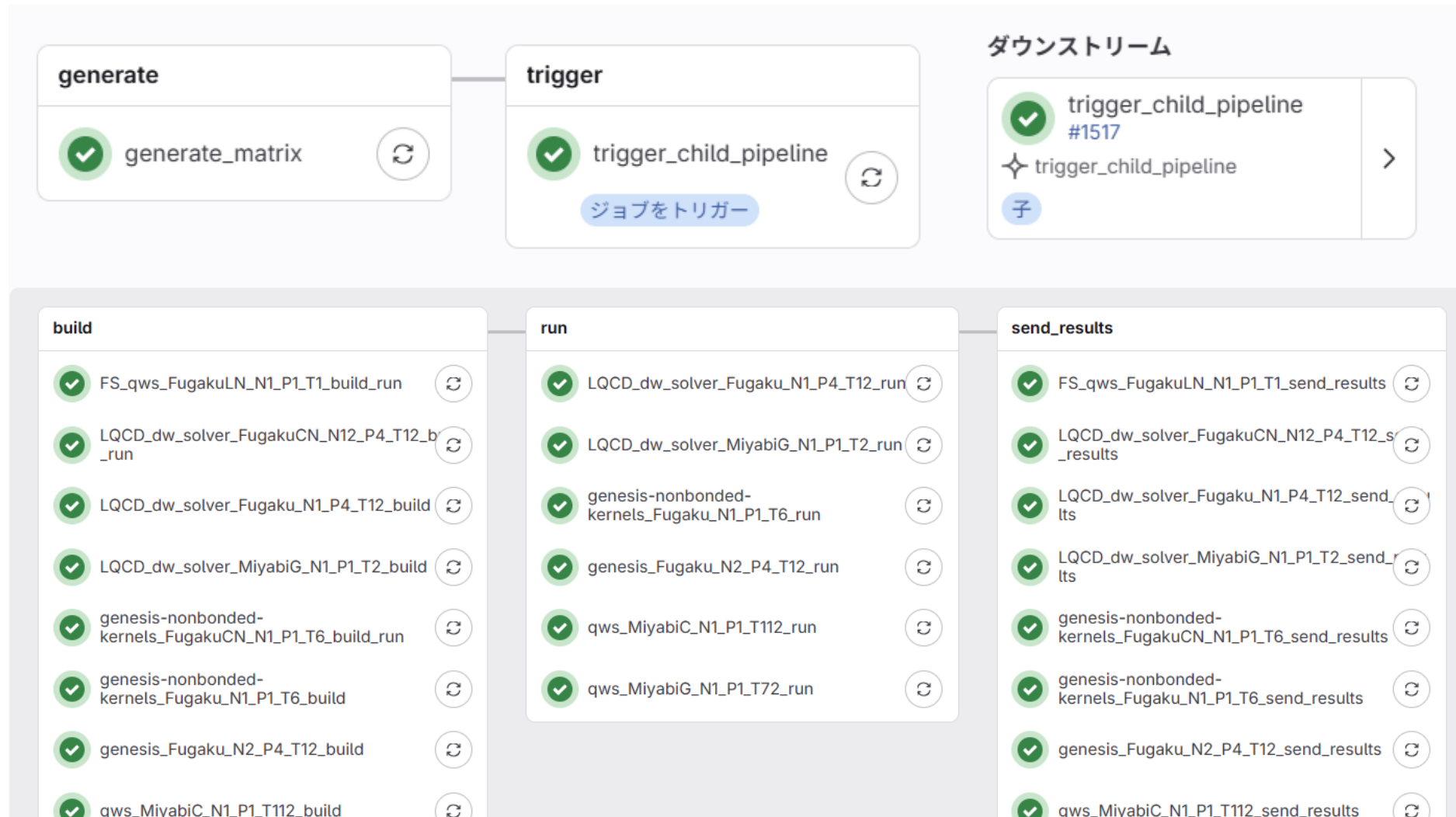

● Automated Execution Results

[Results](#)
[Systems](#)
[Confidential Results](#)
[Estimated Results](#)

Results

Search by multiple keyword

Timestamp	CODE	Exp	FOM	FOM version	SYSTEM	Nodes	JSON	PA Data
2026-01-09 11:15:34	LQCD_dw_solver	total	22.828	LQCD_dw_solver	FugakuCN	12	json	-
2026-01-09 11:15:34	LQCD_dw_solver	solver	22.722338	LQCD_dw_solver	FugakuCN	12	json	-
2026-01-09 11:13:24	LQCD_dw_solver	solver_CUCA	7.277896	LQCD_dw_solver	MiyabiG	1	json	-
2026-01-09 11:13:24	LQCD_dw_solver	total_CUCA	7.479	LQCD_dw_solver	MiyabiG	1	json	-
2026-01-09 11:13:24	LQCD_dw_solver	total_OpenACC	7.389	LQCD_dw_solver	MiyabiG	1	json	-
2026-01-09 11:13:24	LQCD_dw_solver	solver_OpenACC	7.246475	LQCD_dw_solver	MiyabiG	1	json	-
2026-01-09 11:09:23	LQCD_dw_solver	solver	11.358210	LQCD_dw_solver	Fugaku	1	json	-
2026-01-09 11:09:23	LQCD_dw_solver	total	11.470	LQCD_dw_solver	Fugaku	1	json	-
2026-01-09 08:41:49	scale-letkf	SC23_1280x1280	166.177	SCALE-LETKF	Fugaku	75	json	-
2026-01-09 08:37:43	scale-letkf	SC23_128x128	29.847	SCALE-LETKF	Fugaku	3	json	-
2026-01-09 08:25:48	scale-letkf	SC23_128x128	440.728	SCALE-LETKF	RC_GH200	1	json	-